

NOTE:
TOP SLAB REINFORCED TO MEET OR EXCEED REQUIREMENTS OF AASHTO HS20-44 LOADING.

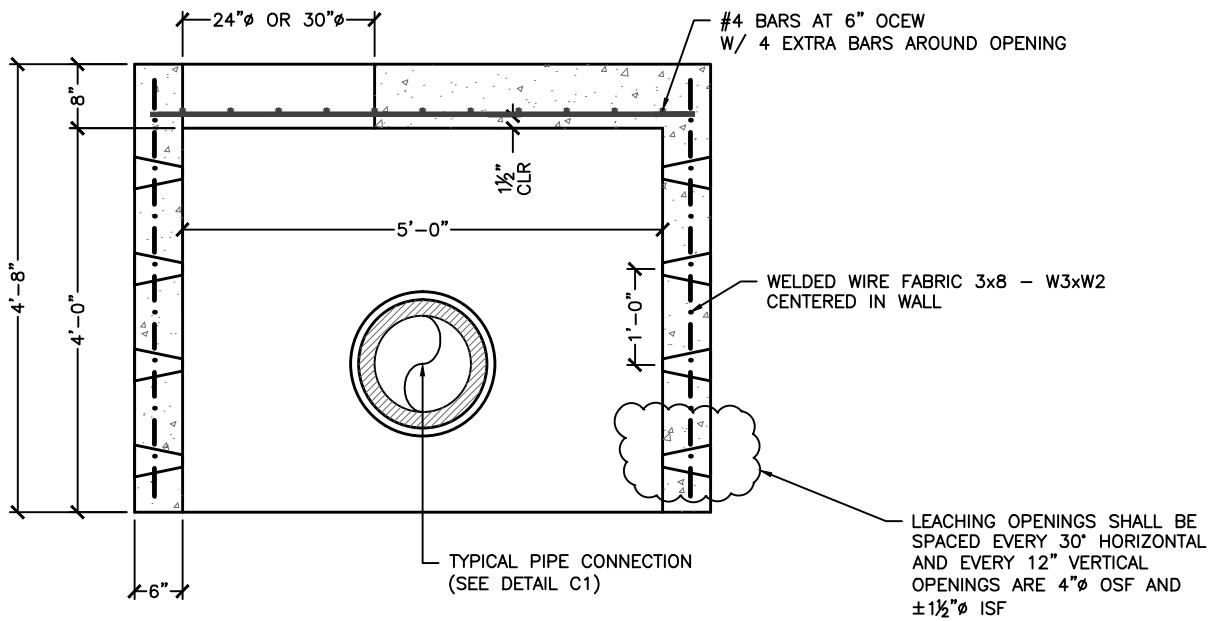

- NOTES:
1. MANUFACTURED TO MEET OR EXCEED REQUIREMENTS OF ASTM C-478 & AASHTO M-199 SPECIFICATIONS.
 2. CIRCUMFERENTIAL REINFORCEMENT SHALL CONFORM TO ASTM A-185. TOP STEEL SHALL CONFORM TO ASTM A-615 GRADE 60 DEFORMED BARS. BOTH PLACED PER ASTM C-478 (8.1, 8.3, 8.4).
 3. CONCRETE: 4,000 PSI MINIMUM @ 28 DAYS, PER ASTM C-478 (6.1). CEMENT TO BE PER ASTM C-150.

Revised: 7/21/14

DWG NO.
S1

Customer:

Project Name:
Project Location:

5' DIAMETER
COMMERCIAL DRY WELL

Project No:

Scale: AS SHOWN

Date:

Designed by:

Drawn by: P/L

Checked by: XXX



173 BUXTON INDUSTRIAL DRIVE-PO BOX 870
HENNIKER, NH 03242
PHONE: 603-428-3218
FAX: 603-428-7426
www.michiecorp.com